

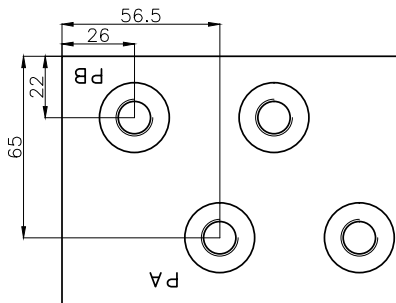

CF3*G380TP

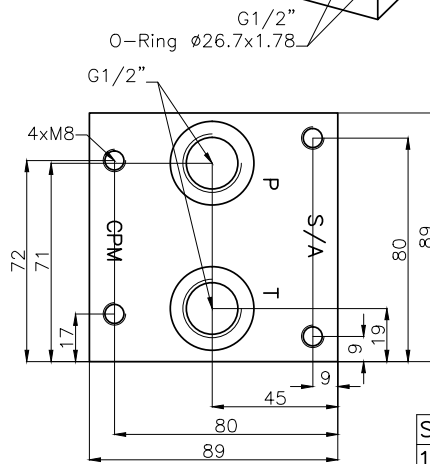
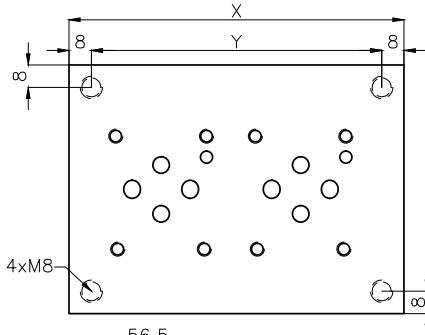
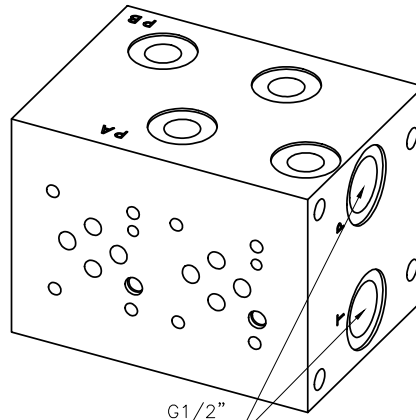
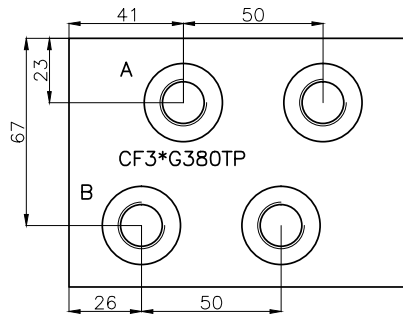

Stat.	X	Y	kg
1	70	54	3.5
2	120	104	6.0
3	170	154	8.5
4	220	204	11.0
5	270	254	13.5
6	320	304	16.0
7	370	354	18.5
8	420	404	21.0

Hydraulic scheme

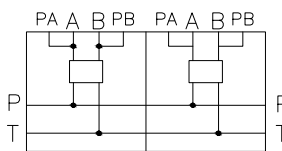

Technical specification

Material: GJS-400-15
 Treatment: ISO9717-MnPh
 Pressure: 300bar
 Flow rate: 50l/min

Designation code:

